

Datasheet T15

Mass Flow Meters for Gases

> Introduction

Bronkhorst High-Tech model T15 Mass Flow Meters (MFMs) are suited for precise measurement of virtually all conventional process gases, even if these contain particulates or traces of moisture. The in-line MFM consists of a thermal mass flow sensor and a microprocessor based pc-board with signal and fieldbus conversion and a PID controller for optional mass flow control by means of a separately mounted control valve. The IN-FLOW^{CTA} model is of rugged design (IP65) for use in industrial environments or even Zone 2 hazardous areas, with optional ATEX Cat. 3 approval. The mass flow, expressed in normal liters per minute or per hour by default, is provided as analog signal or digitally via RS232 or fieldbus. The flow range and wetted materials are determined depending of the type of gas and the process conditions of the application.

> Technical specifications

Measurement / control system

Accuracy (incl. linearity) (based on actual calibration)	: $\pm 1\%$ Rd plus $\pm 1\%$ FS
Repeatability	: $< 0,2\%$ FS typical
Turndown	: 1 : 50 or 1 : 100 (see flow range table)
Operating pressure	: 0...10 bar(g)
Pressure sensitivity	: 0,3% Rd/bar typical at Air
Operating temperature	: 0...50 °C
Temperature sensitivity	: zero: $< \pm 0,1\%$ FS/°C; span: $< \pm 0,2\%$ Rd/°C
Leak integrity (outboard)	: $< 2 \times 10^{-9}$ mbar l/s He
Attitude sensitivity	: max. error at 90° off horizontal 0,2% at 1 bar, typical N ₂
Response time (sensor t _{63%})	: 0,9 sec
Warm-up time	: 30 min. for optimum accuracy 2 min. for accuracy $\pm 2\%$ FS

Mechanical parts

Material (wetted parts)	: SS316; other on request
Process connections	: standard: none; options: compression type or face seal male
Seals	: standard: Viton®; options: EPDM, FFKM (Kalrez®)
Ingress protection (housing)	: IP65

Although all specifications in this datasheet are believed to be accurate, the right is reserved to make changes without notice or obligation.



IN-FLOW^{CTA} Mass Flow Meter model T15

Electrical properties

Power supply	: +15...24 Vdc
Power consumption	: max. 125 mW; add 50 mW for PROFIBUS, if applicable
Analog output	: 0...5 (10) Vdc or 0 (4)...20 mA (sourcing output)
Digital communication	: standard RS232; options: PROFIBUS-DP®, DeviceNet™, Modbus-RTU, FLOW-BUS

Electrical Connections

Analog/RS232	: 8-pin DIN male
PROFIBUS-DP®	: bus: 5-pin DIN male; power: 8-DIN male
DeviceNet™	: 5-pin M12 male
Modbus-RTU/FLOW-BUS	: 5-pin M12 male

> Ranges (based on Air)

Model	minimum	maximum
T15	10...500 l _n /min	50...5000 l _n /min

Intermediate ranges are available

> Model number identification

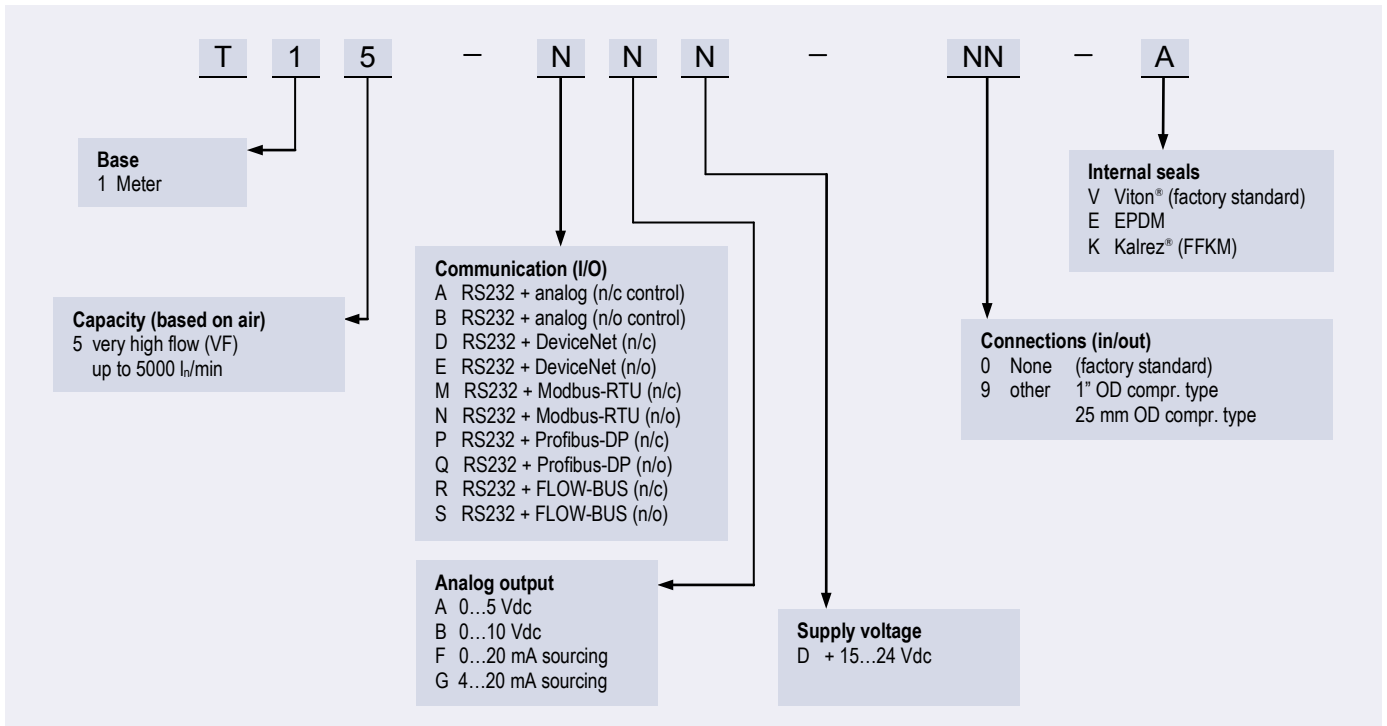

> Thermal mass flow measuring principle

IN-FLOW^{CTA} Mass Flow Meters with inline sensor (no by-pass) consist of a straight flow channel, into which two stainless steel probes protrude; a heater probe and a temperature sensor probe. A constant temperature (ΔT) is created between the two probes and the energy required to maintain this ΔT is proportional to the mass flow rate. Based on this concept, mass flow can be measured with low pressure drop, mainly caused by the gas fittings and the mesh screens which are incorporated for flow conditioning (see figure below). Compared to traditional thermal MFMs and MFCs with by-pass, the construction of the direct measuring CTA principle (Constant Temperature Anemometry) is less sensitive to humidity and contamination.

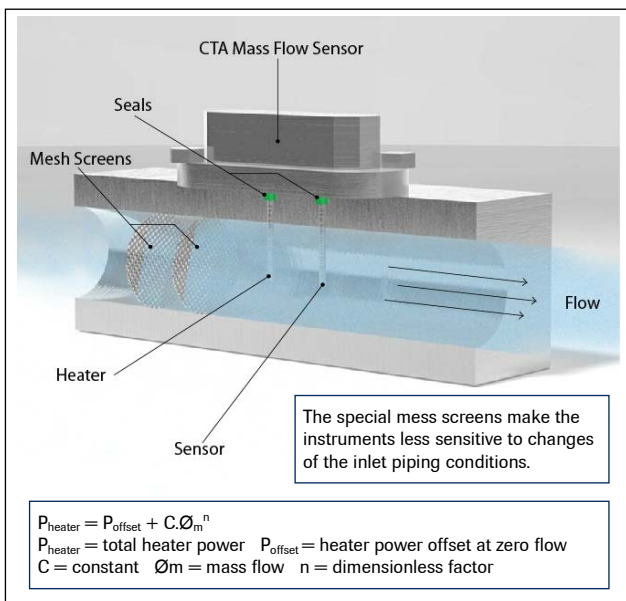

Functional scheme of the thermal mass flow sensor

> State of the art digital design

Today's IN-FLOW^{CTA} series are equipped with a digital pc-board, offering high accuracy, excellent temperature stability and fast response. The basic digital pc-board contains all of the general functions needed for measurement and control. In addition to the standard RS232 output the instruments also offer analog I/O. Furthermore, an integrated interface board provides DeviceNetTM, PROFIBUS-DP[®], Modbus-RTU or FLOW-BUS protocols.

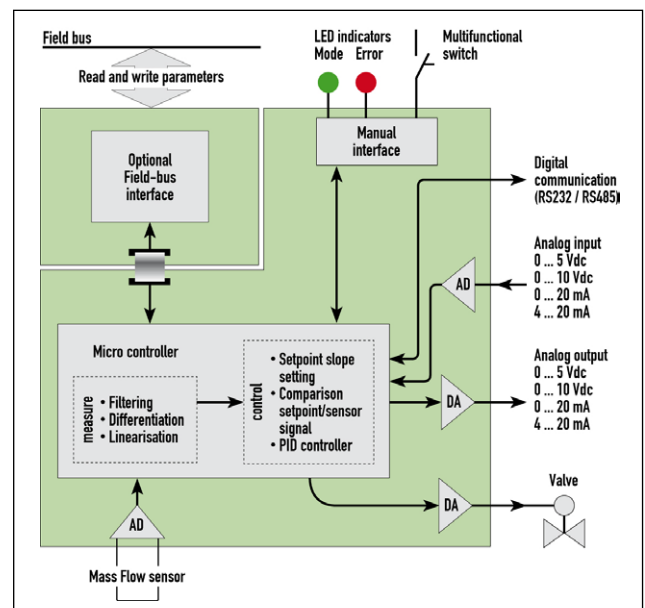

Functional scheme of the digital PC-board

> Hook-up diagram for analog or RS232 communication

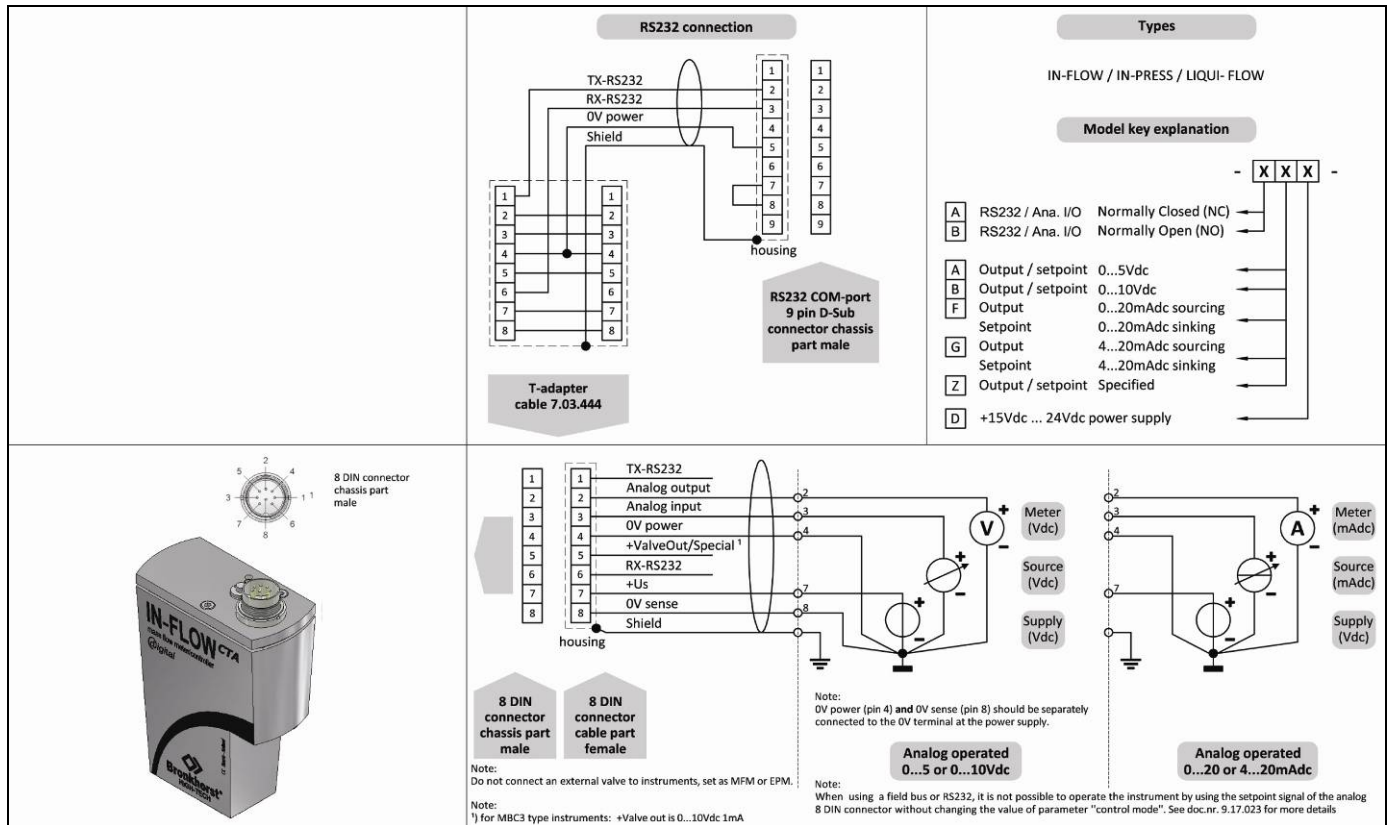

> Hook-up diagrams for fieldbus communication

For the available fieldbus options we refer to the various hook-up diagrams as indicated below. If you are viewing this datasheet in digital format, you may use the hyperlink to each of the drawings. Otherwise please visit the download section on www.bronkhorst.com or contact our local representatives.

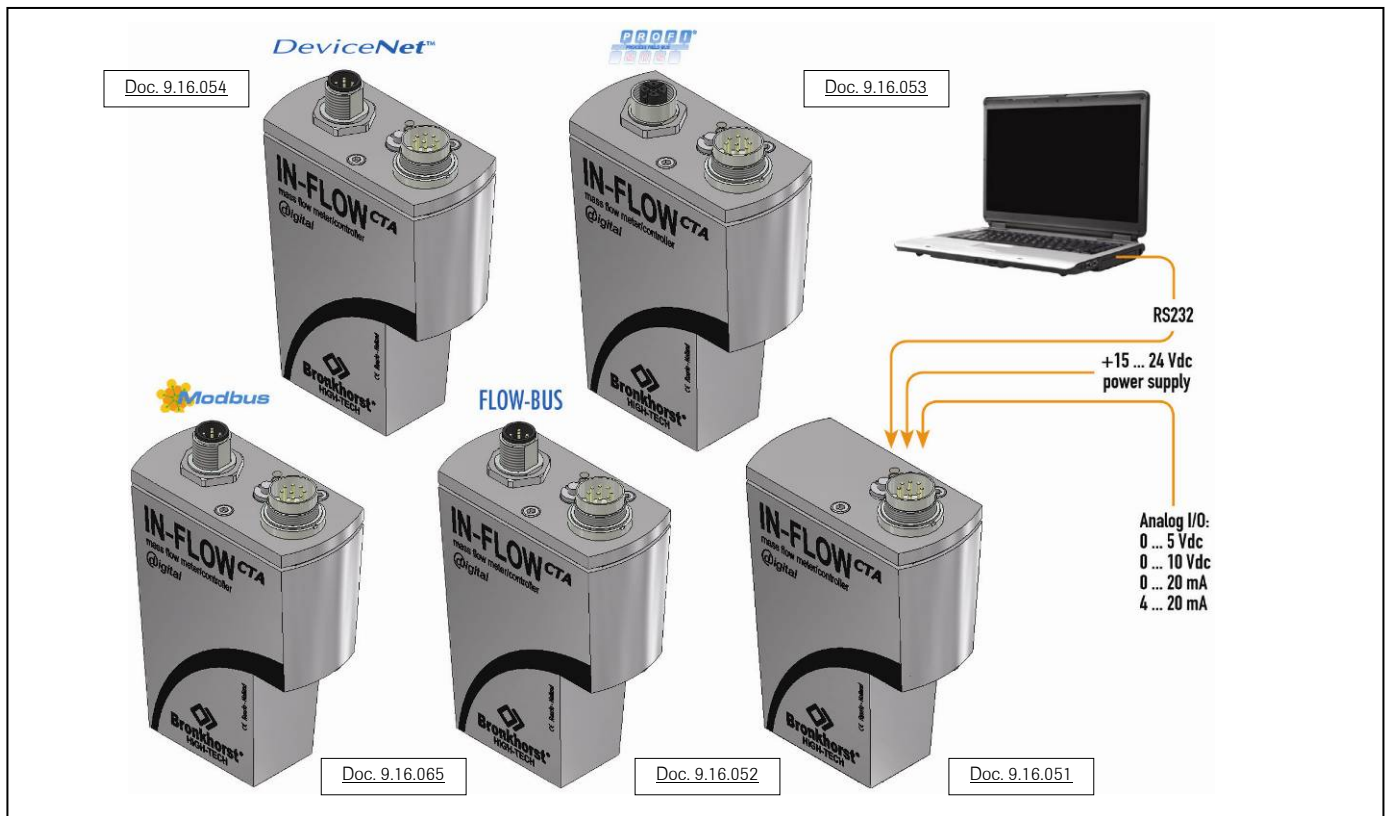

> Dimensions (mm) and weight (kg)

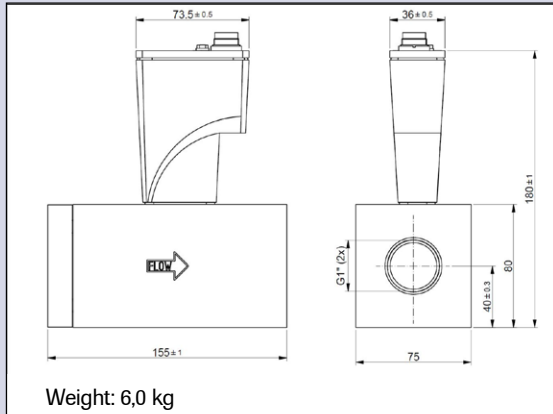

Dimension table adapters (RS-type)

Compression type	1"BSPP	
	Size A	
adapter 25 mm OD		41.7
adapter 1" OD		41.7

*) Dimension A is typical finger-tight.

> Options and accessories

- Free software support for operation, monitoring, optimizing or to interface between digital instruments and windows software.	
- BRIGHT compact local Readout/Control module - E-5700 / E-7000 Power Supply	
- Interconnecting cables for power and analog/digital communication - PiPS Plug-in Power Supply	
- Optional ATEX Zone 2 Cat. 3 protection. Hereto we will furnish extra cover(s) for mechanical impact protection (see pictures), including applicable certificate(s).	

> Alternatives

- IN-FLOW ^{CTA} direct (no by-pass) Mass Flow Meter model T14 (capacities from 100 up to 1000 l _n /min Air-equivalent Full Scale)	
- LOW-ΔP-FLOW series F-106Z (by-pass style) Mass Flow Meter for low pressure drop applications or corrosive gas service (capacities up to 1000 m ³ _n /h Air-equivalent)	